

ALARM SENSING MODULE

ALM-1000

For Visual, Audible and Remote Indications of Alarm Conditions

The ALM-1000 provides an indication of an alarm condition that occurs in any **Liteway**® fiber optic transmission module to which it is connected. When an alarm condition is sensed, a red indicator LED on the unit begins to blink and an audible beeper begins to sound. In addition, a set of SPDT contacts are activated for the operation of a remote device.

The ALM-1000 may be used to detect the loss of a signal, or to detect the occurrence of a broken fiber depending on the module it is connected to. The unit may be used in either a stand-alone mode or mounted to any of the RMP- series of rack mounting panels.



Technical Specifications

Important Features

Compatibility	Any Litelink ™ module
Visual Indicator	Blinking Red LED
Audible Indicator	Beeping Piezo Sounder
Controls*	Sounder On/Off
Remote Alarm Contacts	SPDT
Contact Ratings	115VAC/DC 2 amperes
Remote contact Connector	Removable Terminal Block
Operating Temperature	-35° to +75°C
Humidity	<95% non condensing
MTBF (per MIL HBK 217)	>120,000 hours
Power Requirements*	11-24 VAC/DC @ 100 mA
Physical Size (mm)	5.0" (127) x 3.0" (76) x 1.0" (25.4)

* Red Alarm LED and Remote Alarm Contacts cannot be turned off. Note that all specifications are subject to change without prior notice.

- **Visual and Audible Indications**
- **Remote SPDT Alarm Contacts**
- **Stand-alone or Rack Mountable (same unit)**

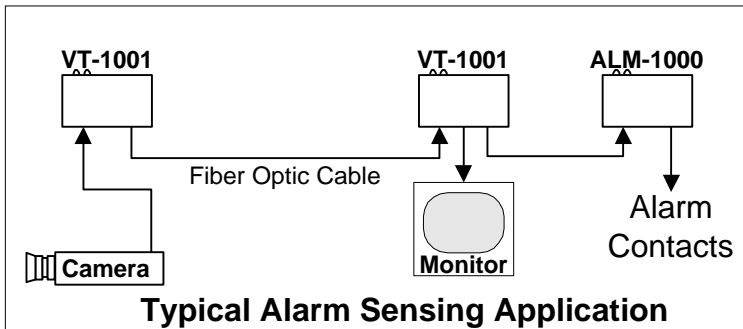

Typical Alarm Sensing Application

Ordering Information

Alarm Sensing Module

ALM-1000

*For stand-alone operation order a PS-1205 power supply.

*For rack mounted operation all operating power is provided by the power supply used with the rack panel.

Liteway®
Fiber Optic Transmission Systems

www.Liteway.com
USA 516-931-2800